

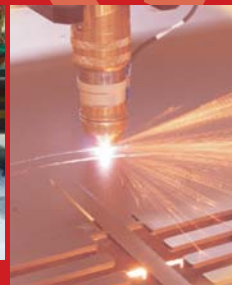

CUTTING ACCESSORIES

切割消耗件



渤洱康自动化设备（上海）有限公司

VULCAN AUTOMATIC EQUIPMENT (SHANGHAI) CO., LTD



Contents 目录

| 03 | **PLASMA CUTTING PART**
等离子切割配件

- KOIKE
- HYPERTHERM
- ESAB
- TANAKA
- Kjellberg

| 20 | **GAS CUTTING PART**
气体切割配件

- GAS CUTTING TIP (KOIKE-TYPE)
- GAS CUTTING TIP (106-D7, 103-D7)

| 22 | **PLASMA AIR PART**
空气等离子切割配件

- OTC D-12000
- P-80A

| 23 | **LASER CUTTING PART**
激光切割配件

| 24 | **CUTTING SPARE**
其他切割配件

- PLASMA ACCESSORIES PART
等离子切割附件部分
- PLASMA MANUFACTURED LIST
等离子切割产品辅具

| 28 | **GAS CUTTING SPARE**
气体切割配件

| 29 | **MARKING SPARE**
划线消耗件

Plasma Cutting Part

等离子切割配件

TW-254 APT [KOIKE KPC 254]

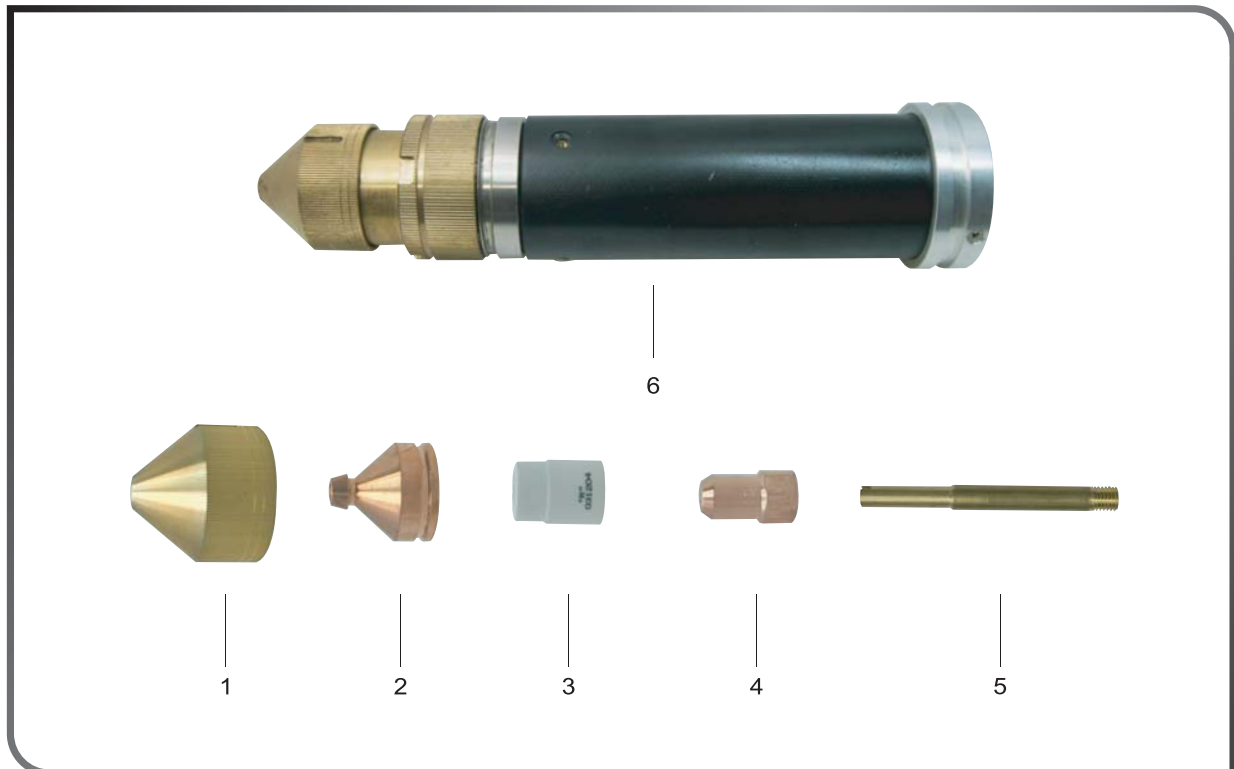

TW-254 APT KOIKE KPC 254

Item No.	Ref No. 参考号	Part No. 型号	Description	品名	StdPkg
1	OB-06-K	TW-OB-06-K	Guard Cap	外帽	1
2	OB-03-A23	TW-OB-03-A23	Insert Tip	喷嘴	1
3	PK031204	TW-PK031204	Centering Stone R	涡流环 R	1
	PK031205	TW-PK031205	Centering Stone L	涡流环 L	1
4	PK031027	TW-PK031027	Electrode (A-type)	电极 (A型)	1
5	254-11-A	TW-254-11-A	Water Pipe	水管	1
6	-	-	Torch Ass'y	枪炬总成	1

Plasma Cutting Part

等离子切割配件

TW-400 OPS [KOIKE 400 OPS]

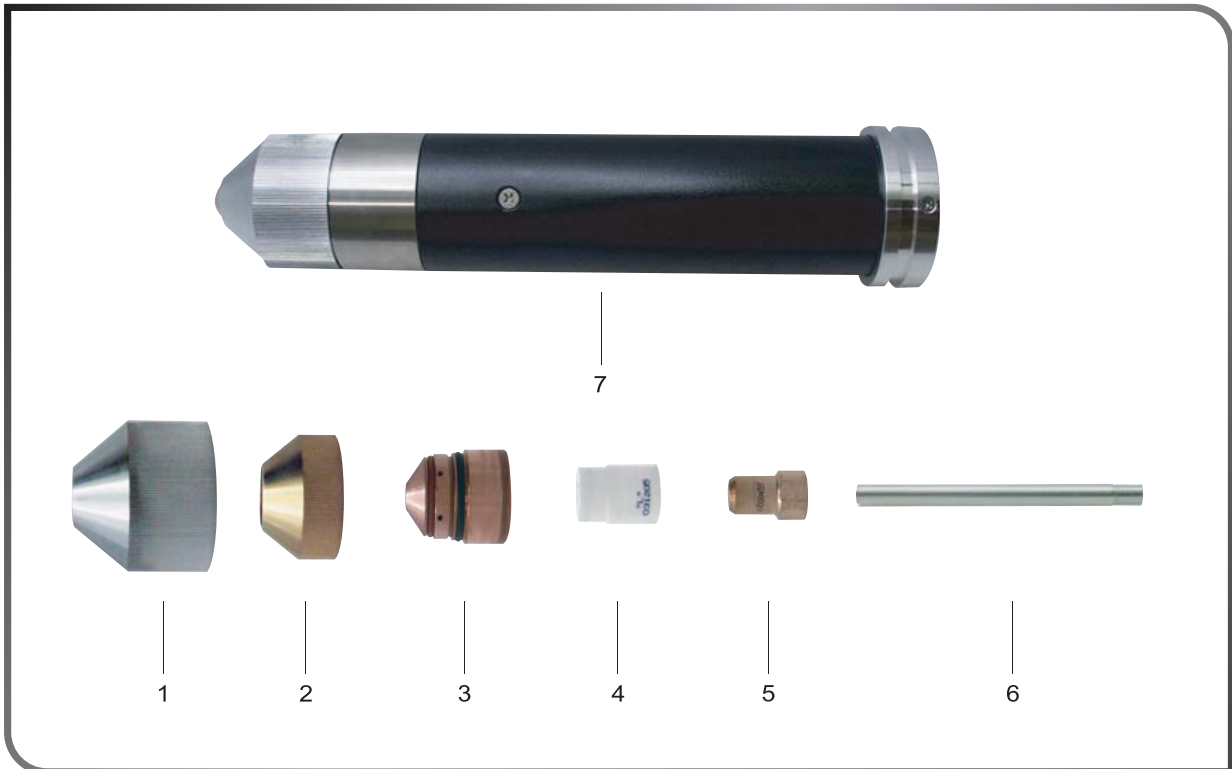

TW-400 OPS KOIKE 400 OPS

Item No.	Ref No. 参考号	Part No. 型号	Description	品名	StdPkg
1	PK031360	TW-031360	Guard Cap	外帽	1
2	PK031323	TW-031323	Insert Cap	内帽	1
3	PK030060	TW-030060	Tip 2.5 R	喷嘴 2.5 R	1
	PK030062	TW-030062	Tip 2.5 L	喷嘴 2.5 L	1
	PK030061	TW-030061	Tip 3.0 R	喷嘴 3.0 R	1
	PK030063	TW-030063	Tip 3.0 L	喷嘴 3.0 L	1
4	PK031204	TW-031204	Centering Stone R	涡流环 R	1
	PK031205	TW-031205	Centering Stone L	涡流环 L	1
5	PK031027	TW-031027	Electrode (A-Type)	电极(A型)	1
	PK40008459	TW-40008459	Electrode (T-Type)	电极(T型)	1
6	PK405152	TW-405152	Water Pipe	水管	1
7	-	-	Torch Ass'y	枪炬总成	1

TW-402 OPS [KOIKE 402 OPS]

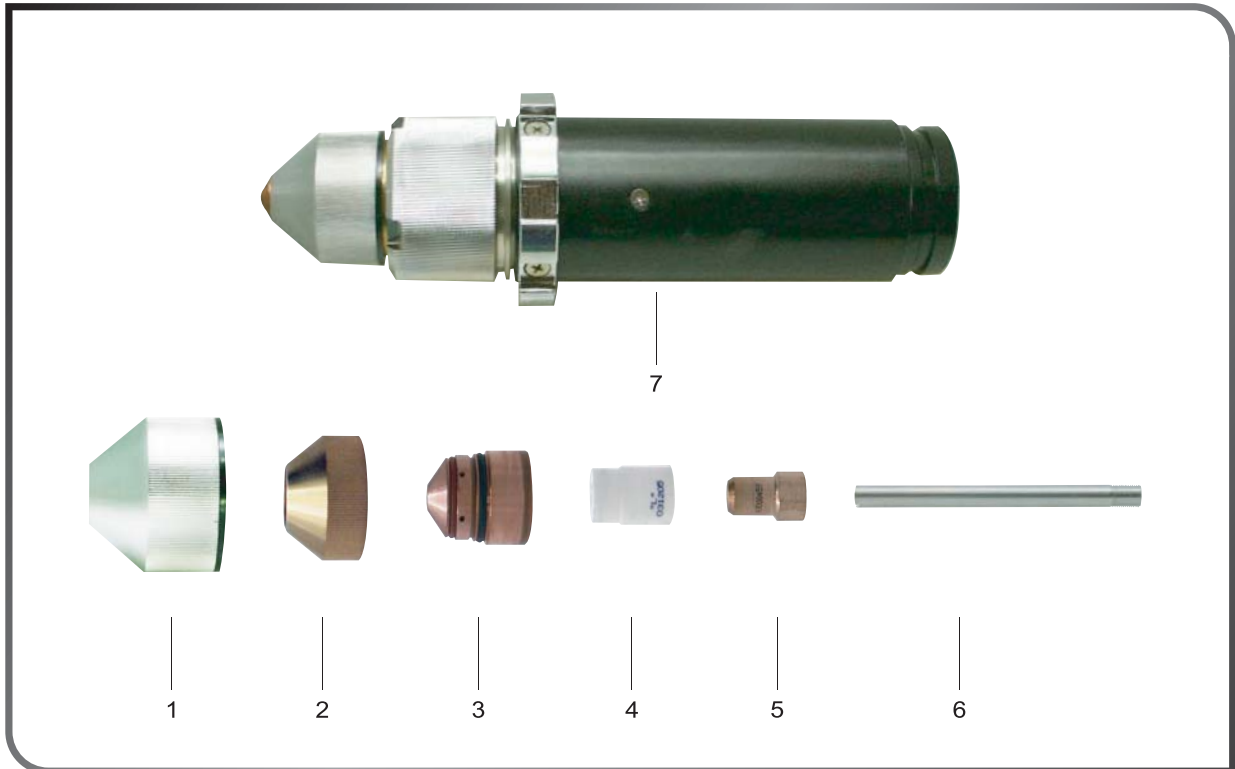

TW-402 OPS KOIKE 402 OPS

Item No.	Ref No. 参考号	Part No. 型号	Description 品名	StdPkg
1	PK031324	TW-031324	Guard Cap 外帽	1
2	PK031323	TW-031323	Insert Cap 内帽	1
3	PK030060	TW-030060	Tip 2.5 R 喷嘴 2.5 R	1
	PK030062	TW-030062	Tip 2.5 L 喷嘴 2.5 L	1
	PK030061	TW-030061	Tip 3.0 R 喷嘴 3.0 R	1
	PK030063	TW-030063	Tip 3.0 L 喷嘴 3.0 L	1
4	PK031204	TW-031204	Centering Stone R 涡流环 R	1
	PK031205	TW-031205	Centering Stone L 涡流环 L	1
5	PK031027	TW-031027	Electrode (A-Type) 电极 (A型)	1
	PK40008459	TW-40008459	Electrode (T-Type) 电极 (T型)	1
6	PK405152	TW-405152	Water Pipe 水管	1
7	-	-	Torch Ass'y 枪炬总成	1

Plasma Cutting Part

等离子切割配件

TW-410 OPS [KOIKE 410 OPS]

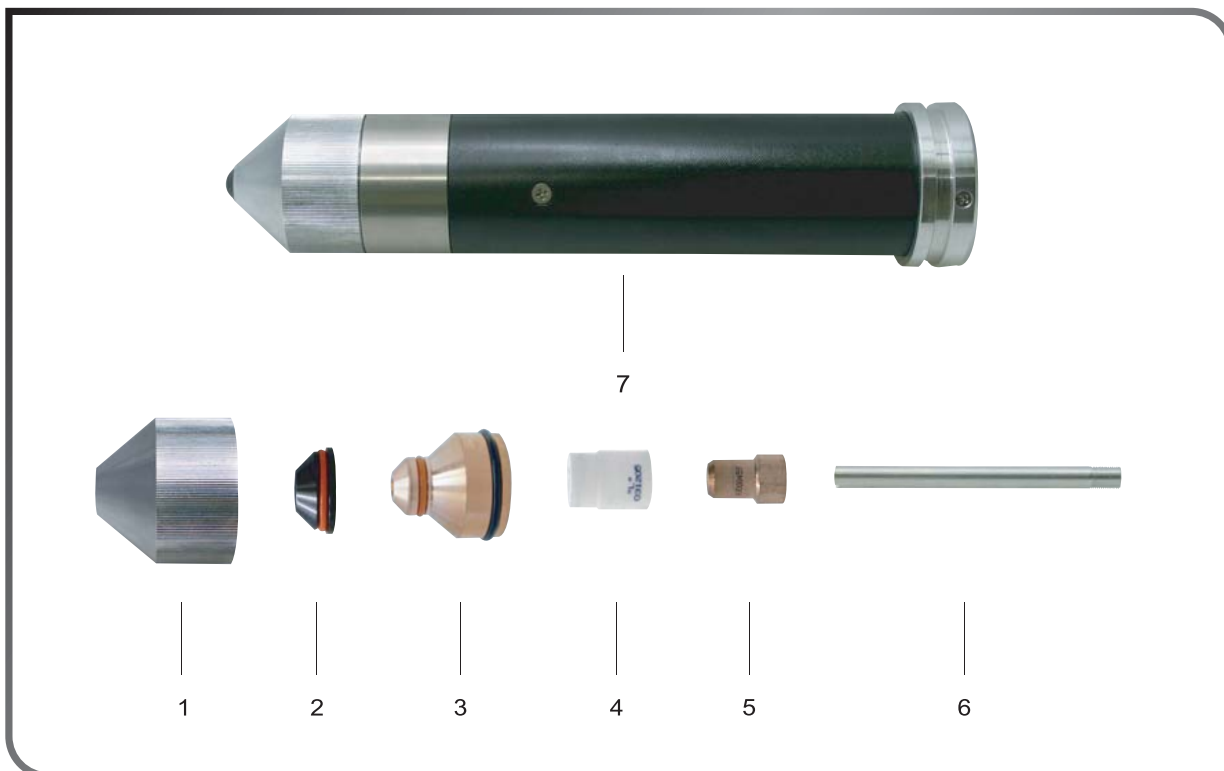

TW-410 OPS KOIKE 410 OPS

Item No.	Ref No. 参考号	Part No. 型号	Description 品名	StdPkg
1	PK031370	TW-031370	Guard Cap 外帽	1
2	PK031326	TW-031326	UD Cap UD帽	1
3	PK030076	TW-030076	Tip 1.8 喷嘴 1.8	1
	PK030077	TW-030077	Tip 2.0 喷嘴 2.0	1
	PK030078	TW-030078	Tip 2.3 喷嘴 2.3	1
4	PK031204	TW-031204	Centering Stone R 涡流环 R	1
	PK031205	TW-031205	Centering Stone L 涡流环 L	1
5	PK031027	TW-031027	Electrode (A-Type) 电极 (A型)	1
6	-	-	Water Pipe 水管	1
7	-	-	Torch Ass'y 枪炬总成	1

TW-434 [OPS PLUS]

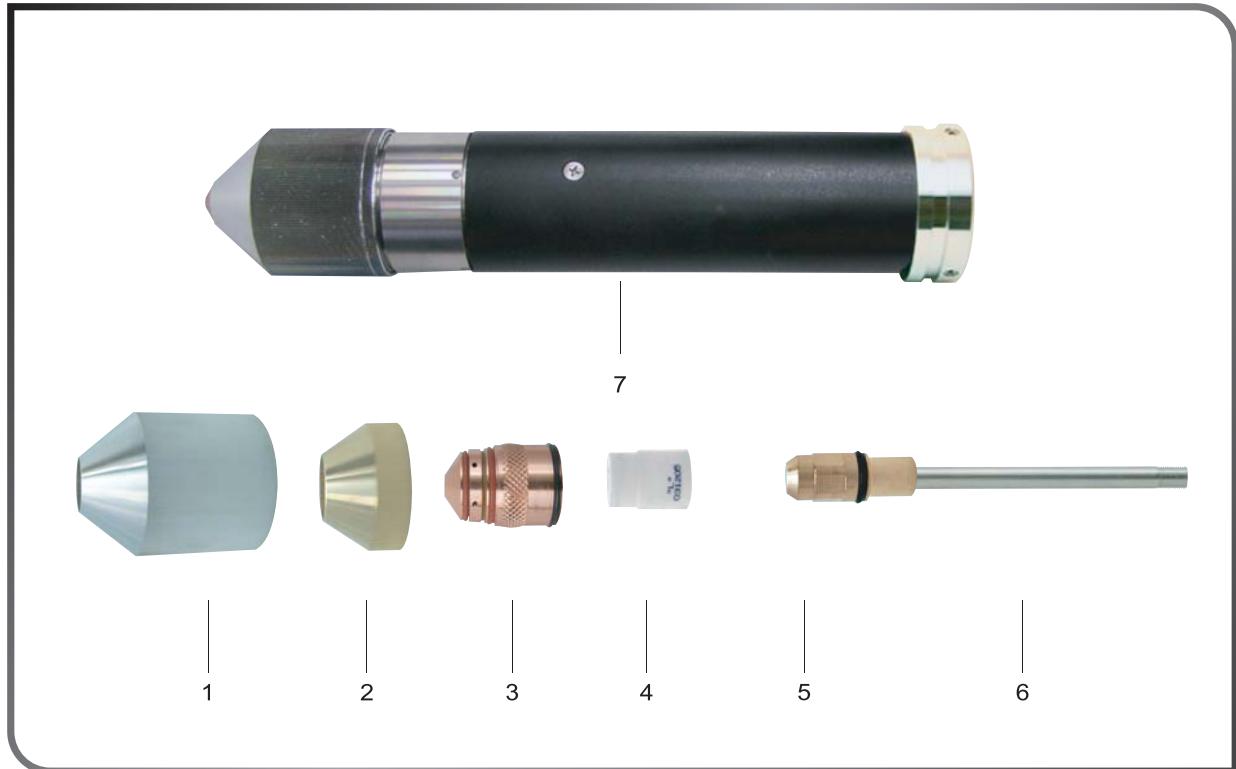

TW-434 OPS PLUS

Item No.	Part No. (431) 参考号	Part No. (433/434) 型号	Description 品名	StdPkg
1	TW-40016365	TW-40020503	Guard Cap 外帽	1
2	TW-40016366	TW-40016366	Insert Cap 内帽	1
3	TW-40016359	TW-40016359	Tip 1.7 R 喷嘴1.7 R	1
	TW-40016362	TW-40016362	Tip 1.7 L 喷嘴1.7 L	1
	TW-40016360	TW-40016360	Tip 2.3 R 喷嘴2.3 R	1
	TW-40016363	TW-40016363	Tip 2.3 L 喷嘴2.3 L	1
	TW-40016361	TW-40017233	Tip 2.9 R 喷嘴2.9 R	1
	TW-40016364	TW-40017234	Tip 2.9 L 喷嘴2.9 L	1
4	TW-PK031204	TW-40001899	Centering Stone R 涡流环 R	1
	TW-PK031205	TW-40004567	Centering Stone L 涡流环 L	1
5	TW-40016358	TW-40016358	Electrode 电极	1
6	-	-	Water Pipe 水管	1
7	-	-	Torch Ass'y 枪炬总成	1

Plasma Cutting Part

等离子切割配件

TW-600 OPS [KOIKE 600 OPS]

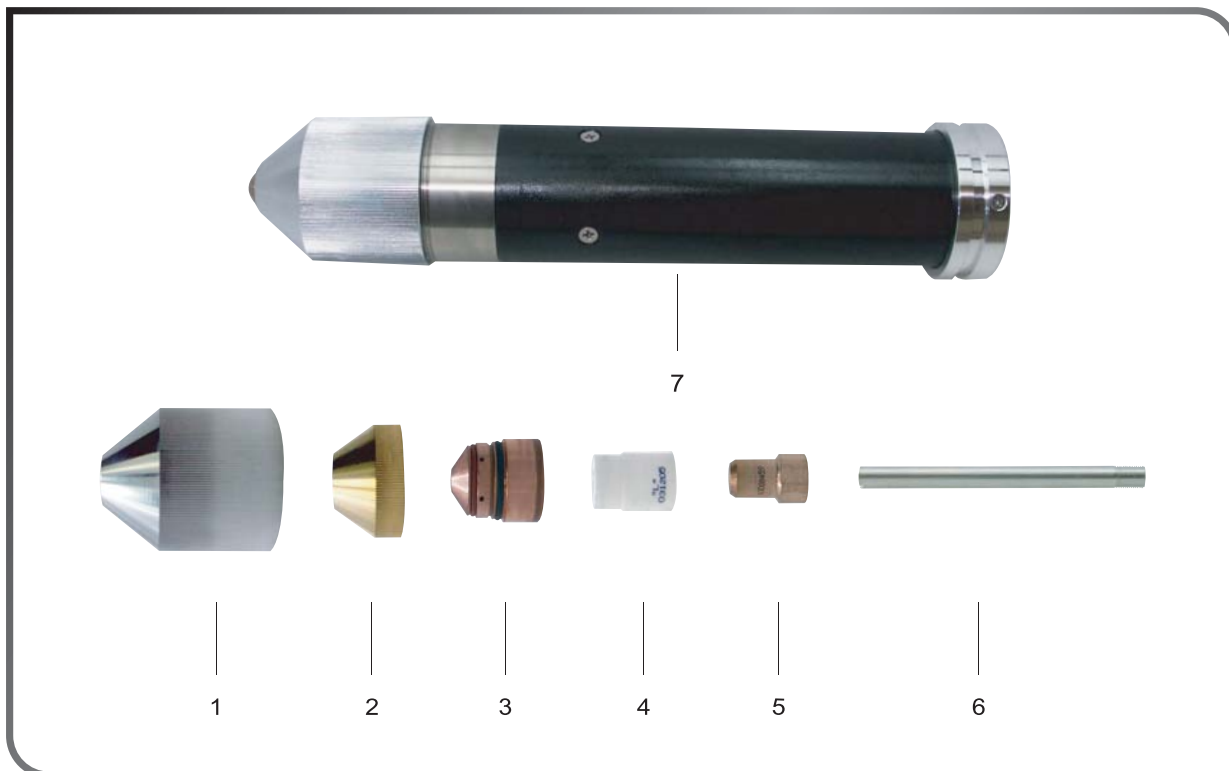

TW-600 OPS KOIKE 600 OPS

Item No.	Ref No. 参考号	Part No. 型号	Description 品名	StdPkg
1	PK031336	TW-031336	Guard Cap 外帽	1
2	PK031332	TW-031332	Insert Cap 内帽	1
3	PK030060	TW-030060	Tip 2.5 R 喷嘴2.5 R	1
	PK030062	TW-030062	Tip 2.5 L 喷嘴2.5 L	1
	PK030061	TW-030061	Tip 3.0 R 喷嘴3.0 R	1
	PK030063	TW-030063	Tip 3.0 L 喷嘴3.0 L	1
4	PK031204	TW-031204	Centering Stone R 涡流环 R	1
	PK031205	TW-031205	Centering Stone L 涡流环 L	1
5	PK40008459	TW-40008459	Electrode (T-Type) 电极 (T型)	1
6	-	-	Water Pipe 水管	1
7	PK40005054	TW-40005054	Torch Ass'y 枪炬总成	1

TW-MAX200 [HYPERTHERM MAX200]

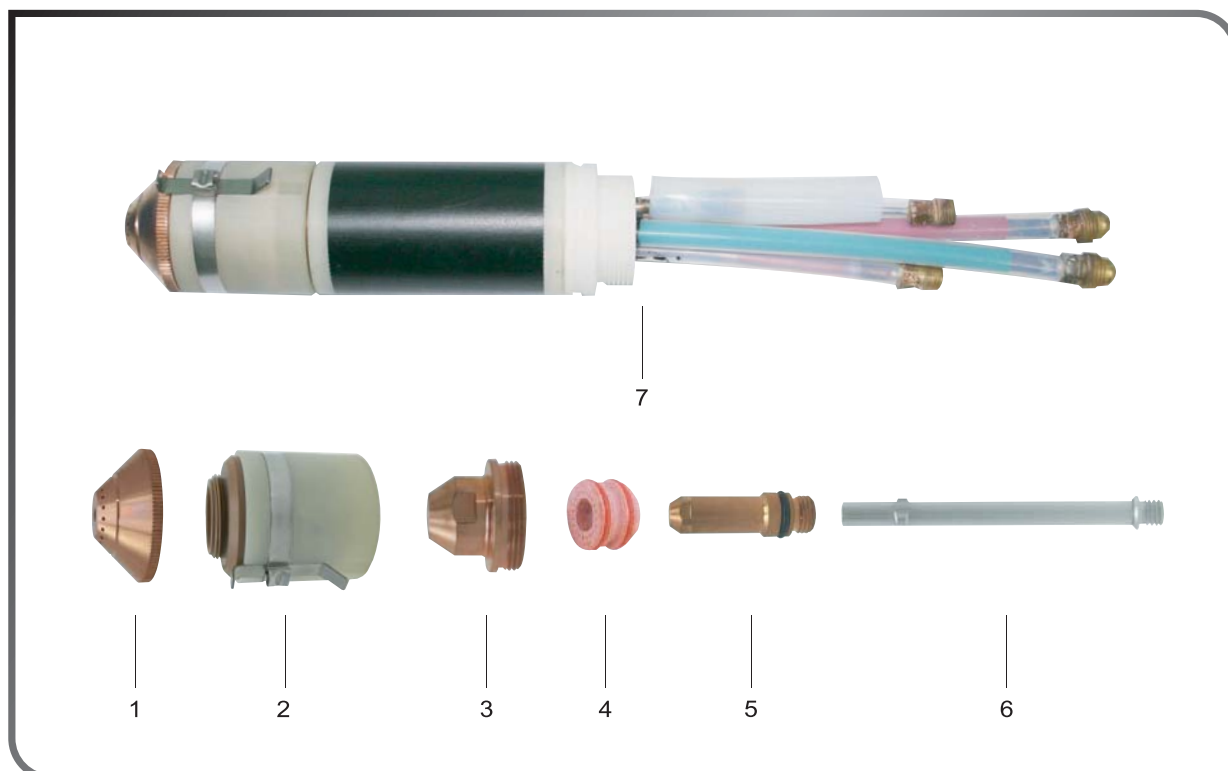

TW-MAX200 HYPERTHERM MAX200

Item No.	Ref No. 参考号	Part No. 型号	Description	品名	StdPkg
1	020566	TW-020566	Shield, Water Muf.200A	防护罩	1
2	020423	TW-020423	Retaining Cap	保护帽	1
3	020605	TW-020605	Nozzle 200A , 082Oxygen	喷嘴 200A, 082氧气	1
4	020607	TW-020607	Swirl Ring	涡流环	1
5	220021	TW-220021	Electrode, Air/Oxy	电极, 空气/氧气	1
6	020963	TW-020963	Water Cooling Tube	水管	1
7	128380	TW-128380	Torch Body	割枪	1

Plasma Cutting Part

等离子切割配件

TW-HT2000 [HYPERTHERM HT2000 - BEVEL 用]

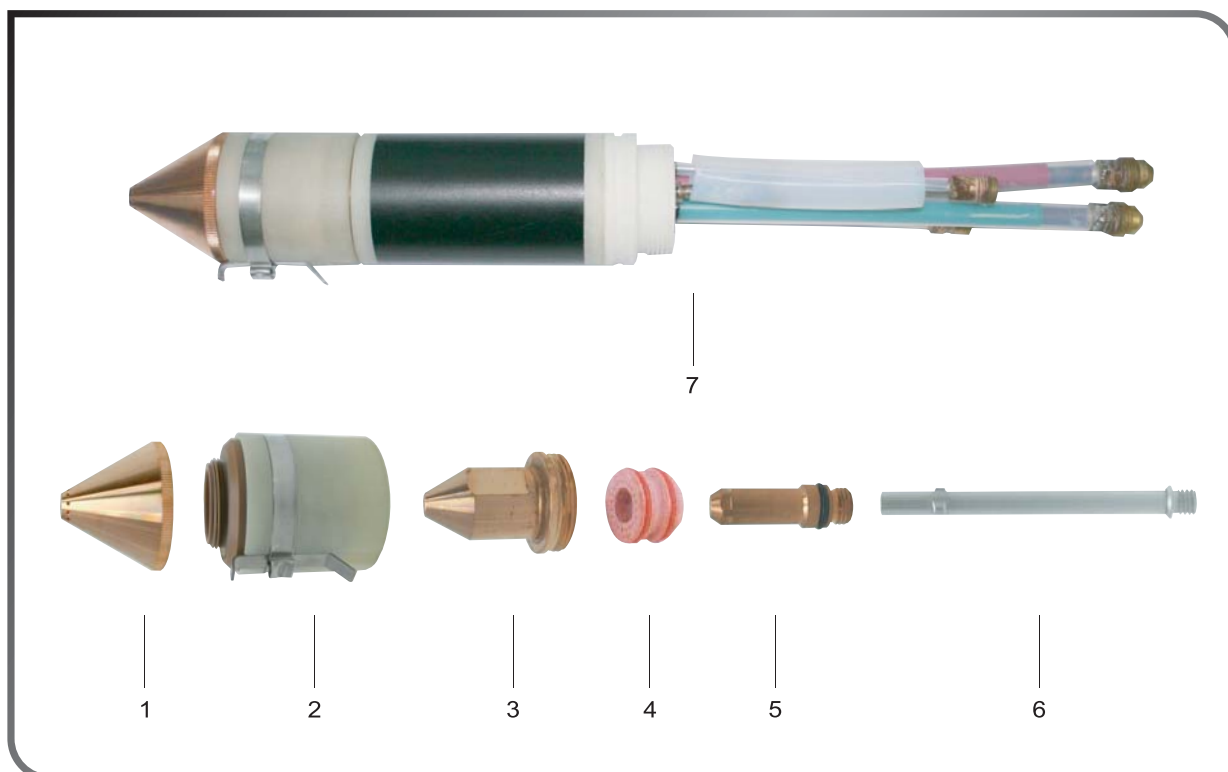

TW-HT2000 HYPERTHERM HT2000-BEVEL 用

Item No.	Ref No. 参考号	Part No. 型号	Description	品名	StdPkg
1	120260	TW-120260	Shield 200A	防护罩 200A	1
2	020423	TW-020423	Retaining Cap	保护帽	1
3	120259	TW-120259	Nozzle 200A Oxygen	喷嘴 200A 氧气	1
4	120833	TW-120833	Swirl Ring	涡流环	1
5	120258	TW-120258	Electrode Oxygen	电极 氧气	1
6	020963	TW-020963	Water Cooling Tube	水管	1
7	128380	TW-128380	Torch Body	割枪	1

TW-HT2000 [Hyspeed 2000]

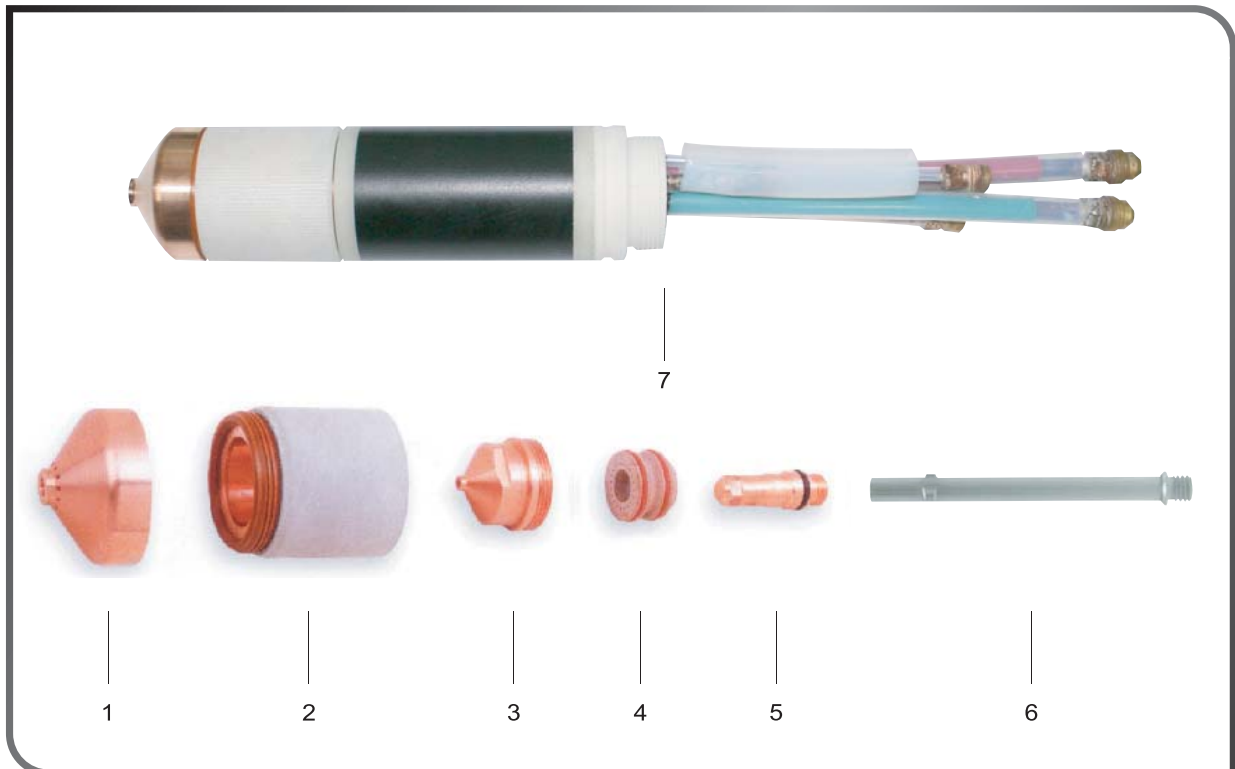

TW-HT2000 Hyspeed 2000

Item No.	Ref No. 参考号	Part No. 型号	Description	品名	StdPkg
1	220239	TW-220239	Shield	防护罩	1
2	220238	TW-220238	Retaining Cap	保护帽	1
3	220237	TW-220237	Nozzle	喷嘴	1
4	220236	TW-220236	Swirl Ring	涡流环	1
5	220235	TW-220235	Electrode	电极	1
6	020963	TW-020963	Water Cooling Tube	水管	1
7	128380	TW-128380	Torch Body	割枪	1

Plasma Cutting Part

等离子切割配件

TW-HT4100 [HYPER THERM HT4100]

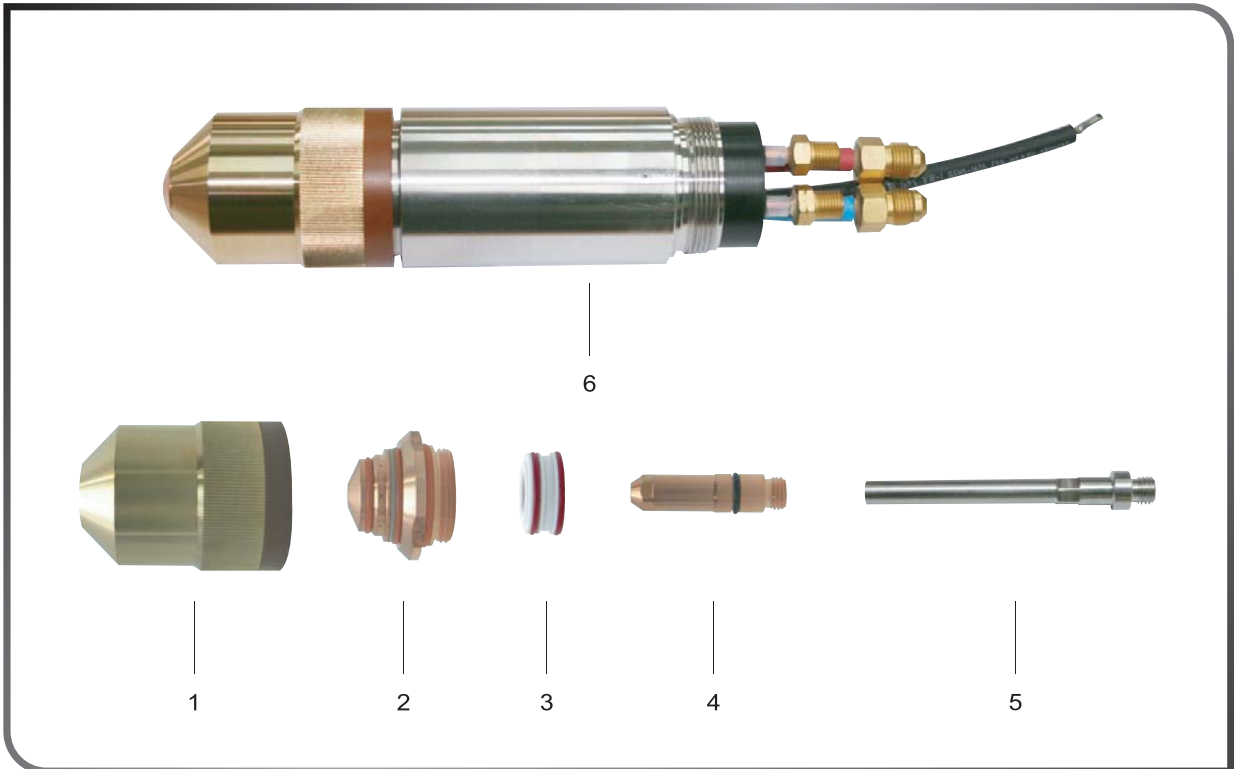

TW-HT4100 HYPER THERM HT4100

Item No.	Ref No. 参考号	Part No. 型号	Description	品名	StdPkg
1	020718	TW-020718	Nozzle Retaining Cap	喷嘴保护帽	1
2	020719	TW-020719	Nozzle (cw, ccw)	喷嘴 (cw, ccw)	1
3	020876	TW-020876	Swirl Ring CCW	涡流环 CCW	1
	020720	TW-020720	Swirl Ring CW	涡流环 CW	1
4	020721	TW-020721	Electrode	电极	2
5	120025	TW-120025	Water Cooling Tube	水管	1
6	-	TW-410001	Torch Body	割枪	1

TW-HT4400 [HYPERTHERM HT4400]

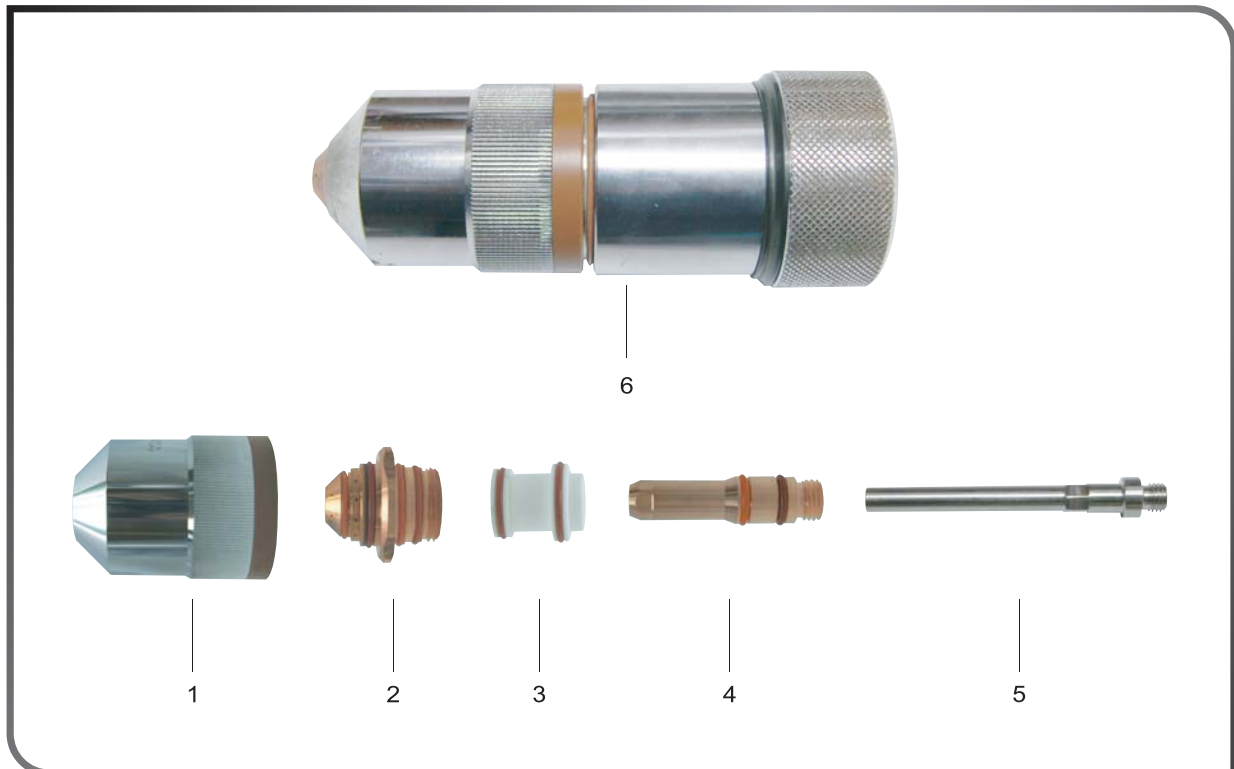

TW-HT4400 HYPERTHERM HT4400

Item No.	Ref No. 参考号	Part No. 型号	Description	品名	StdPkg
1	120786	TW-120786	Retaining Cap	保护帽	1
2	120787	TW-120787	Nozzle 200A CW	喷嘴 200A CW	1
	120788	TW-120788	Nozzle 200A CCW	喷嘴 200A CCW	1
	120794	TW-120794	Nozzle 300A CW	喷嘴 300A CW	1
	120795	TW-120795	Nozzle 300A CCW	喷嘴 300A CCW	1
	120934	TW-120934	Nozzle 400A CW	喷嘴 400A CW	1
	120935	TW-120935	Nozzle 400A CCW	喷嘴 400A CCW	1
3	120939	TW-120939	Swirl Ring CW	涡流环 CW	1
	120940	TW-120940	Swirl Ring CCW	涡流环 CCW	1
4	120793	TW-120793	Electrode 200A	电极 200A	1
	120802	TW-120802	Electrode 300A	电极 300A	1
	120810	TW-120810	Electrode 400A	电极 400A	1
5	120025	TW-120025	Water Cooling Tube	水管	1
6	-	-	Torch Ass'y	割枪	1

Plasma Cutting Part

等离子切割配件

TW-PT-19XL [ESAB PT-19XL]

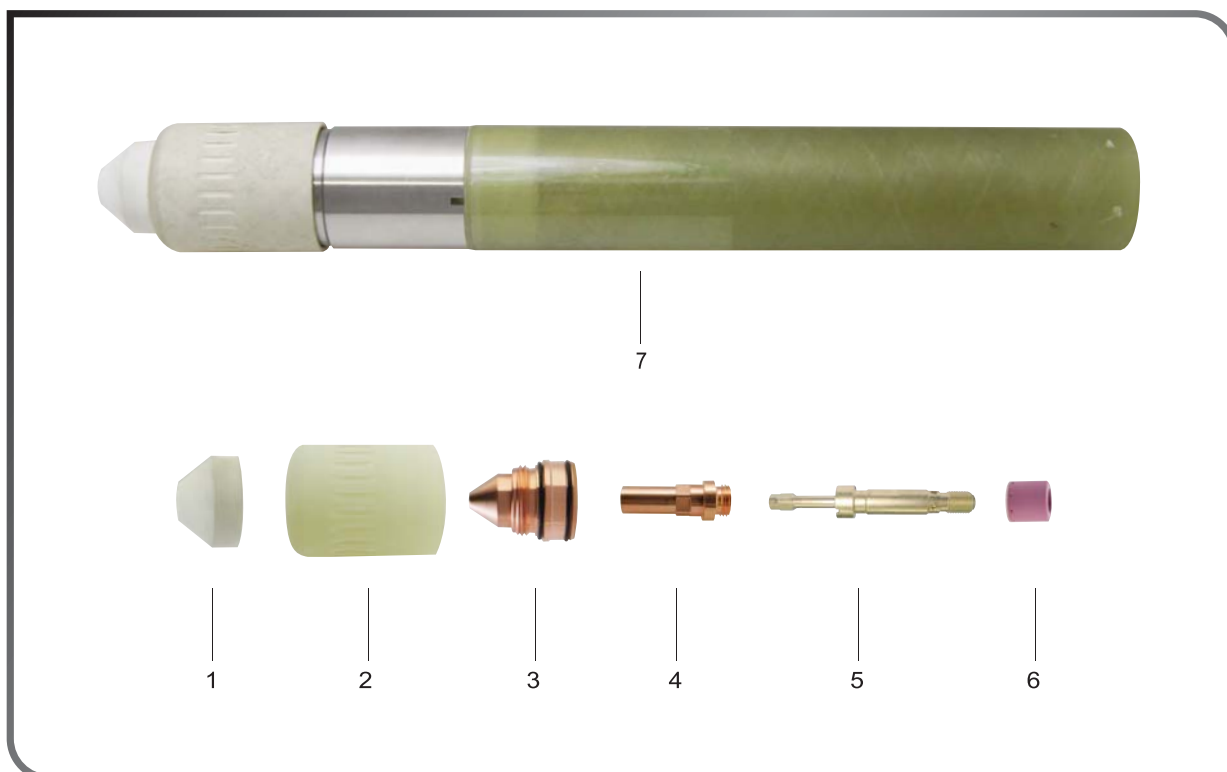

TW-PT-19XL ESAB PT-19XL

Item No.	Ref No. 参考号	Part No. 型号	Description	品名	StdPkg
1	948186	TW-948186	Heat Shield	防护罩	1
2	34085	TW-34085	Retainer Cap	保护帽	1
3	21822	TW-21822	Nozzle 250A	喷嘴 250A	1
	35885	TW-35885	Nozzle 360A	喷嘴 360A	1
4	34086XL	TW-34086XL	Electrode 250A	电极 250A	1
	35886XL	TW-35886XL	Electrode 360A	电极 360A	1
5	34084	TW-34084	Electrode Holder	电极座	1
6	35660	TW-35660	Swirl Baffle 8Hole, Std	涡流环8孔, 标准	1
	35661	TW-35661	Swirl Baffle 8Hole, Rev	涡流环8孔, 相反	1
7	20391	TW-20391	Torch Body	割枪	1

TW-PT-600 [ESAB PT-600]

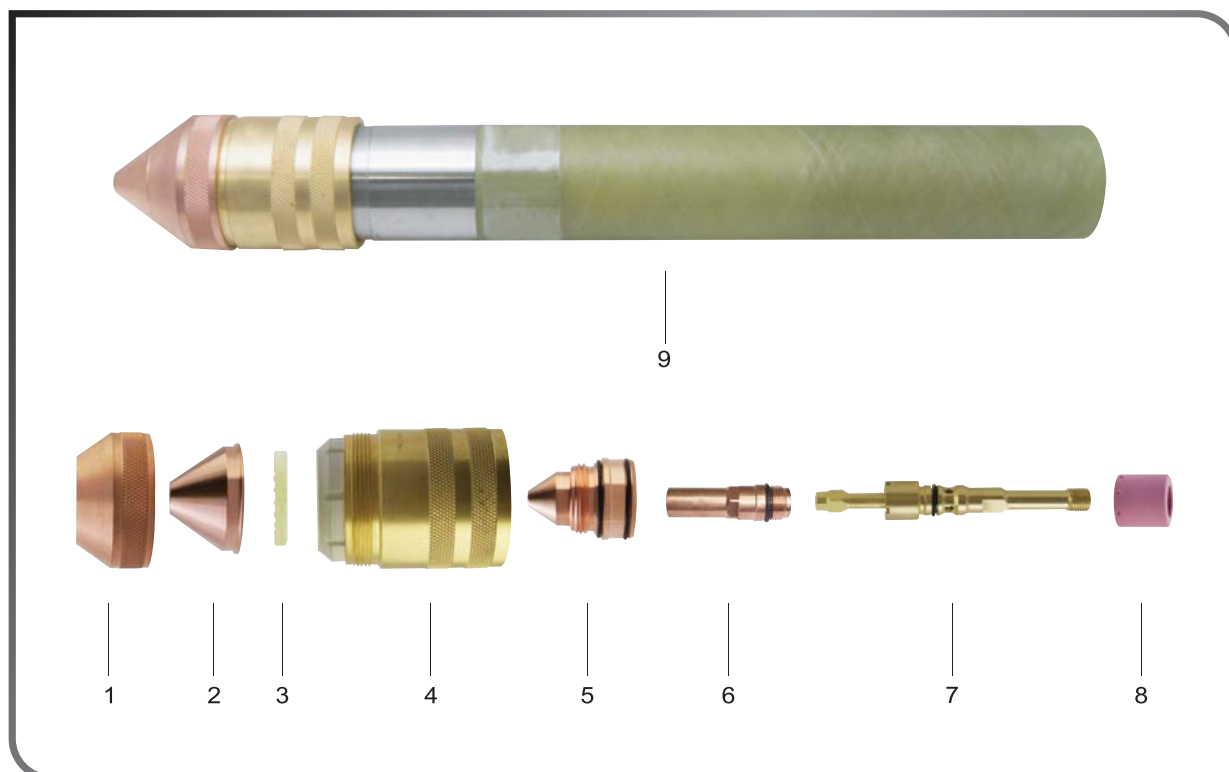

TW-PT-600 ESAB PT-600

Item No.	Ref No. 参考号	Part No. 型号	Description	品名	StdPkg
1	37081	TW-37081	Shield Retainer	外帽	1
2	21945	TW-21945	Shield 360A	内帽 360A	1
3	21944	TW-21944	Diffuser	扩散器	1
4	37082	TW-37082	Nozzle Retainer Cap	喷嘴保护帽	1
5	0558001885	TW-0558001885	Nozzle 360A	喷嘴 360A	1
6	0558002516	TW-0558002516	Electrode 360A/400A	电极 360A/400A	1
7	0558001621	TW-0558001621	Electrode Holder	电极座	1
8	0558001625	TW-0558001625	Gas Baffle	涡流环	1
9	0558001825	TW-0558001825	Torch Body	割枪	1

Plasma Cutting Part

等离子切割配件

TW-FY-500[TANAKA]

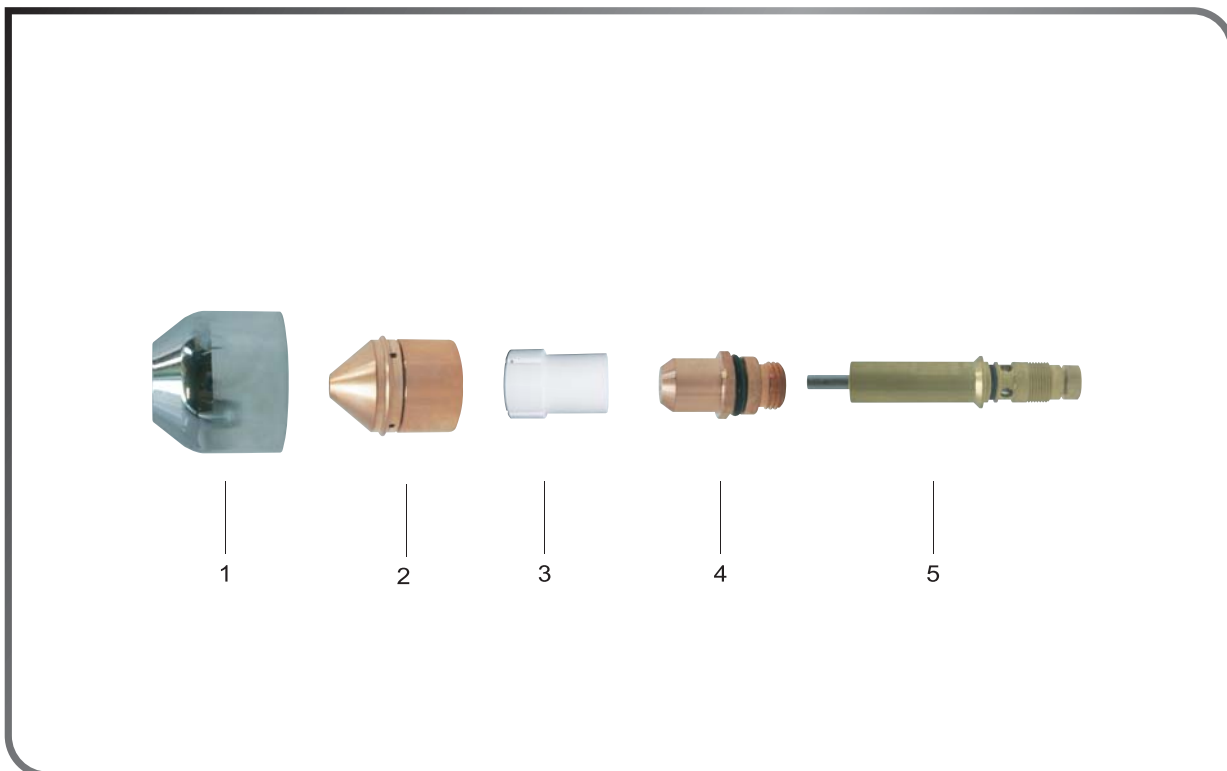

TW-FY-500 TANAKA

Item No.	Ref No. 参考号	Part No. 型号	Description	品名	StdPkg
1	K026277	TW-K026277	Intert Cap	外帽	1
2	-	TW-30R/L	Nozzle / Sus	喷嘴 / Sus	1
	-	TW-50R/L	Nozzle / Sus	喷嘴 / Sus	1
	B467345	TW-300R	Nozzle / 300R	喷嘴 / 300R	1
	B467374	TW-300L	Nozzle / 300L	喷嘴 / 300L	1
	B467344	TW-400R	Nozzle / 400R	喷嘴 / 400R	1
	B467373	TW-400L	Nozzle / 400L	喷嘴 / 400L	1
	B467345	TW-500R	Nozzle / 500R	喷嘴 / 500R	1
	B467374	TW-500L	Nozzle / 500L	喷嘴 / 500L	1
3	K026320	TW-K026320	Swirler liner L	涡流环 L	1
	K026316	TW-K026316	Swirler liner R	涡流环 R	1
4	A467342	TW-A467342	Electrode	电极	1
5	K026309	TW-K026309	Electrode Holder	电极座	1

TW-PB-S76 [Kjellberg P-S76]

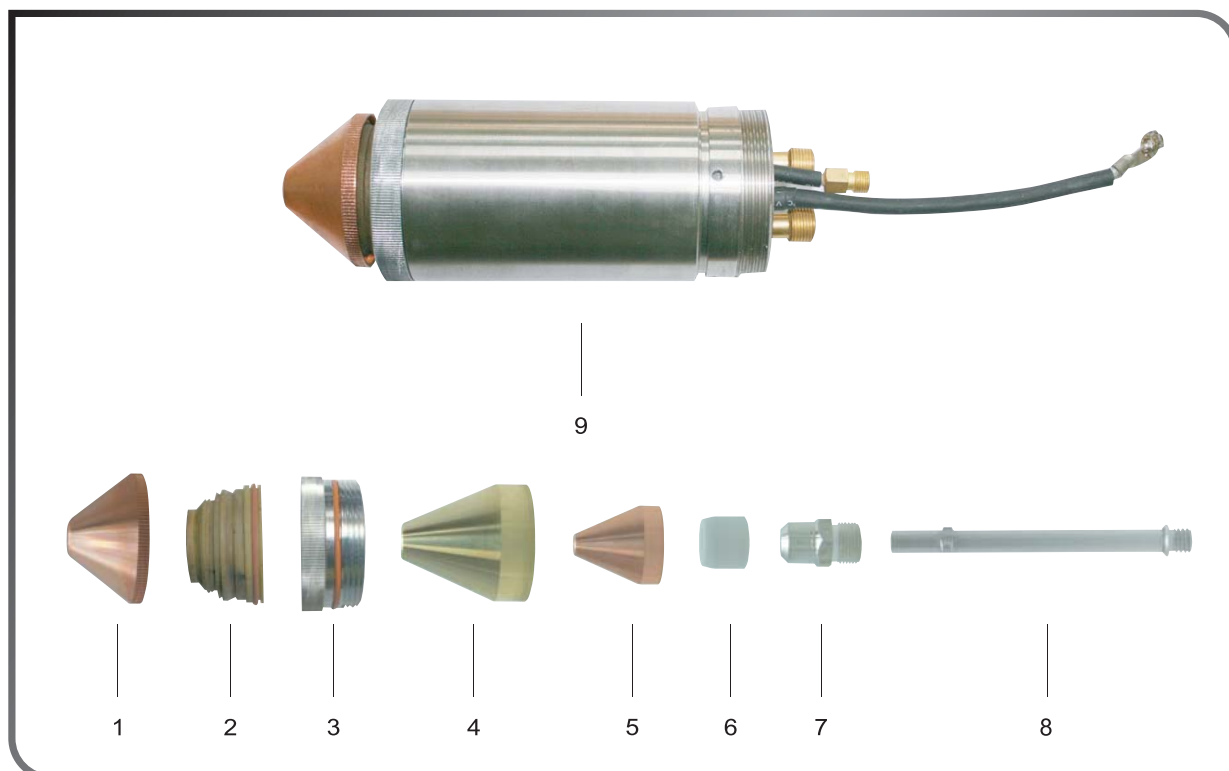

TW-PB-S76 Kjellberg P-S76

Item No.	Ref No. 参考号	Part No. 型号	Description	品名	StdPkg
1	01.01.13	TW-01.01.13	Swril-Gas Cap	外帽	1
2	01.01.10	TW-01.01.10	Swril-Gas Nozzle	内帽	1
3	01.01.12	TW-01.01.12	Protective Cap	保护帽	1
4	01.01.08	TW-01.01.08	Nozzle Cap	喷嘴帽	1
5	01.01.06	TW-01.01.06	Nozzle L1	喷嘴 L1	1
	01.01.06	TW-01.01.06	Nozzle L2	喷嘴 L2	1
6	01.01.04	TW-01.01.04	Gas Guide	涡流环	1
7	01.01.03	TW-01.01.03	Cathode	电极	1
8	01.01.02	TW-01.01.02	Cooling Tube	水管	1
9	01.01.01	TW-01.01.01	Torch Body	割枪	1

Plasma Cutting Part

等离子切割配件

TW-PB-S80 [Kjellberg S-80]

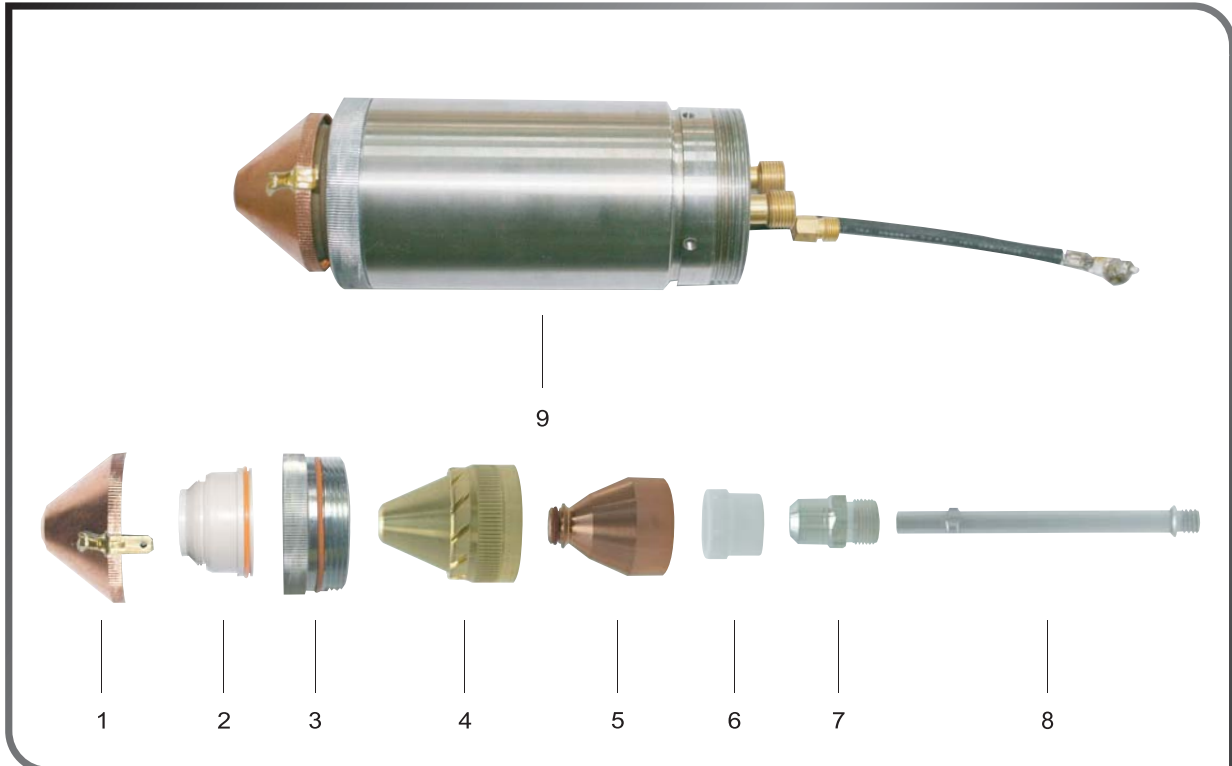

TW-PB-S80 Kjellberg S-80

Item No.	Ref No. 参考号	Part No. 型号	Description 品名	StdPkg
1	01.12	TW-01.12	Swril-Gas Cap 外帽	1
2	01.09	TW-01.09	Swril-Gas Nozzle 内帽	1
3	01.11	TW-01.11	Protective Cap 保护帽	1
4	01.07	TW-01.07	Nozzle Cap 喷嘴帽	1
5	01.05	TW-01.05	Nozzle (T2125) 喷嘴 (T2125)	1
	01.05	TW-01.05	Nozzle (T2127) 喷嘴 (T2127)	1
	01.05	TW-01.05	Nozzle (T2130) 喷嘴 (T2130)	1
6	01.03	TW-01.03	Gas Guide 涡流环	1
7	01.02	TW-01.02	Cathode 电极	1
8	01.01	TW-01.01	Cooling Tube 水管	1
9	01 01	TW-01.01	Torch Body 割枪	1



Gas Cutting Part
气体切割配件

Plasma Air Part
空气等离子切割配件

Laser Cutting
激光切割配件

Cutting Spare
其他切割配件

Gas Cutting Spare
气体切割配件

Marking Spare
划线消耗件



Gas Cutting Part 气体切割配件

GAS CUTTING TIP [KOIKE-TYPE]

GAS CUTTING TIP [KOIKE-TYPE]

■ TW-106

- For LPG gas 使用液化石油气体
- Standard tips 标准切割喷嘴



■ TW-103

- For Ethylene gas 使用乙烯气体
- Standard tips 标准切割喷嘴

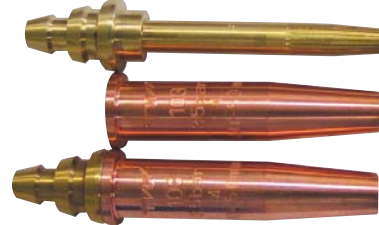

GAS CUTTING TIP [TANAKA-TYPE]

■ TW-3051

- For LPG gas 使用液化石油气体
- Standard tips 标准切割喷嘴



■ TW-3057B

- For LPG gas 使用液化石油气体
- High speed tip 高速切割喷嘴



AUTO GAS CUTTING TIP (106, 103, 3051)

■ FOR LPG, ETHYLENE GAS 用于液化石油气体, 乙烯气体

Plate thickness 板厚 (mm)	Tip-No. 喷嘴编号	Pressure 气压		Consumption 消耗 NL/hr			Cutting speed 切割速度 mm/min
		Oxygen 氧气	Fuel gas 气体燃料	Cutting Oxygen 切割氧气	Preheat Oxygen 预热氧气	Fuel gas 燃料	
0 - 5	00	1.5	0.2	690	800	460	0 - 660
5 - 10	0	2		1200			660 - 550
10 - 15	1	2.5		2100			550 - 490
15 - 30	2	3	0.25	3400	900	500	490 - 400
30 - 40	3			4300			400 - 350
40 - 50	4	3.5	0.35	6500	1200	660	350 - 320
50 - 100	5	4		11000			320 - 200
100 - 150	6	4		15000			200 - 150
150 - 250	7	4.5	0.35	22000	2200	1280	150 - 80
250 - 300	8			28000			80 - 45

GAS CUTTING TIP [106-D7, 103-D7]

GAS CUTTING TIP [106-D7 , 103-D7]

■ TW-106 D7

- For LPG gas 使用液化石油气体
- Divergent high speed tip 高速切割喷嘴
(Cutting oxygen pressure;7kg/cm²) (切割压力: 7kg/cm²)



■ TW-103 D7

- For Ethylene gas 使用乙烯气体
- Divergent high speed tip 高速切割喷嘴
(Cutting oxygen pressure;7kg/cm²) (切割压力: 7kg/cm²)

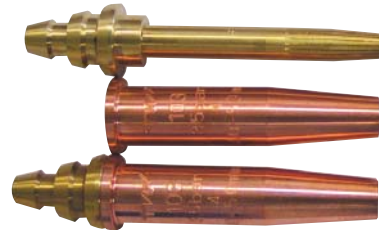

AUTO GAS CUTTING TIP (106-D7, 103-D7)

■ FOR LPG, ETHYLENE GAS 用于液化石油气体, 乙烯气体

Plate thickness 板厚 (mm)	Tip-No. 喷嘴编号	Pressure 气压		Consumption 消耗 NL/hr			Cutting speed 切割速度 mm/min		
		Oxygen 氧气	Fuel gas 气体燃料	Cutting Oxygen 切割氧气	Preheat Oxygen 预热氧气	Fuel gas 燃料			
0 - 5	00	7.0	0.2	750	1120	300	0 - 750		
5 - 10	0			1100			750 - 680		
10 - 15	1			2500			680 - 600		
15 - 30	2		0.25	3800	1300	350	600 - 500		
30 - 40	3			5400			500 - 400		
40 - 50	4		0.35	7300	1850	500	400 - 260		
50 - 100	5			10000			260 - 180		
100 - 150	6			14000			3000	800	260 - 180
150 - 250	7			22000			3650	980	180 - 100
250 - 300	8		31000	100 - 70					

Plasma Air Part

空气等离子切割配件

OTC D-12000 / P-80A

OTC D-12000



ELECTRODE
电极



NOZZLE
喷嘴



CAP
外帽

P-80A



ELECTRODE
电极



NOZZLE
喷嘴



CAP
外帽

Laser Cutting 激光切割配件

Laser Cutting Part



Laser Cutting Part | 激光切割配件

Cutting Spare 其他切割配件

Plasma Accessories Parts 等离子切割附件



TORCH
焊枪



CAP & CERAMIC
外帽类及陶瓷附件



MANUFACTURE ACCESSORIES
加工附件



MARKING TORCHS
划线枪



MAGNETIC TORCH HOLDER
磁力割枪夹具

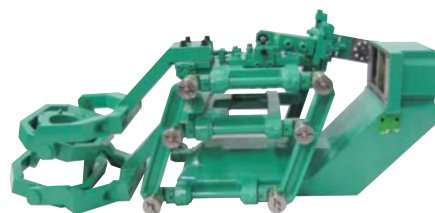

3D LINK ASS'Y
3D链接总成























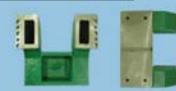











INITIAL SENSOR ASS'Y
初级感应总成



GEAR & TENSION SPRING
齿轮及拉伸弹簧

Cutting Spare \ 其他切割配件

Plasma Manufactured List 等离子切割产品辅具

TW-001  COUPLING CASE 连接壳	TW-002  RING 环	TW-003  BELLOWS 波纹管	TW-003-1  BELLOW ZIPPER 波纹管链
TW-023  SLIDE BLOCK 滑块	TW-033  AIR NOZZLE 气体喷嘴	TW-049  TORCH CLAMP 焊枪夹具	TW-056  RAIL BLUSH 轨道刷
TW-056-1  RAIL BLUSH -1 轨道刷-1	TW-85  LASER SENSOR BOX 激光感应器盒	TW-101  ARM SUPPORT 旋转臂架	TW-101-1  JOINT SUPPORT 连接支架
TW-120  GAS TORCH[300L~500L] 火焰割枪 (300L~500L)	TW-124A  GAS TORCH ASS'Y 火焰割枪总成	TW-124  GAS TORCH HOLDER 火焰割枪夹具	TW-124-1  GAS TORCH HOLDER PIN 火焰割枪固定销
TW-124-2  BACK HOLDER 后夹具	TW-124-3  BACK /FOR HOLDER 前/后夹具	TW-124-4  RACK GEAR 齿轮齿条	TW-124-5  HEX HOLDER 六角夹具
TW-124-6  CIRCLE HOLDER 环形夹具	TW-125  GAS TORCH HOLDER 火焰割枪夹具	TW-131  MARKING TORCH ASS'Y 划线枪总成	TW-131-1  MARKING TORCH [300L~450L] 划线枪 (300~450L)
TW-131-4  MARKING TIP 划线喷嘴 KOIKE TANAKA ESAB	TW-171-2  HOLDER BRACKET 夹具支架	TW-285  TORCH HOLD BRACKET 割枪夹具支架	TW-299  SELECTOR VALVE 切换阀
TW-305  JIG ASS'Y 工装组件	TW-320A  HEIGHT SENSOR ASS'Y 高度传感器组件	TW-320  AIR SENSING NIPPLE 气体传感器接头	TW-330/331  SENSOR JOINT BLOCK 传感器连接块

Cutting Spare

其他切割配件

Plasma Manufactured List 等离子切割产品辅具

<p>TW-339-2</p>  <p>TWIN TORCH 孪生割枪</p>	<p>TW-343</p>  <p>AL BRACKET 铝支架</p>	<p>TW-350</p>  <p>AIR FLEXIBLE TUBE 空气软管</p>	<p>TW-357</p>  <p>SPRING HOLDER 弹簧固定座</p>
<p>TW-359</p>  <p>HOLDER SETTING BRACKET 固定座总成支架</p>	<p>TW-360</p>  <p>GAS CUTTING HOSE 气体切割电缆</p>	<p>TW-370</p>  <p>AIR SENSOR TIP 气体感应喷嘴</p>	<p>TW-371</p>  <p>AIR SENSOR 气体传感器</p>
<p>TW-376</p>  <p>HEIGHT SENSOR BODY 高度传感器本体</p>	<p>TW-378</p>  <p>SENSOR HANDLE SET 传感器支架</p>	<p>TW-381</p>  <p>HEIGHT SENSOR HOLDER 高度传感器夹具</p>	<p>TW-381-1,2</p>  <p>HEIGHT SENSOR BLOCK 高度传感器挡块</p>
<p>TW-385</p>  <p>BRACKET 支架</p>	<p>TW-392</p>  <p>TORCH SENSOR RING 割枪感应环</p>	<p>TW-392-1</p>  <p>TORCH SENSOR RING [3D] 割枪感应环 (3D)</p>	<p>TW-392-BCD</p>  <p>SENSOR SPRING 感应器弹簧</p>
<p>TW-400-10</p>  <p>PLASMA TORCH HOSE 等离子割枪电缆</p>	<p>TW-470</p>  <p>FEDDING BELLOWS 送丝风箱</p>	<p>TW-500</p>  <p>EDGE MILLING HEAD 切割面回转机头</p>	<p>TW-501</p>  <p>SENSOR PIN 感应销</p>
<p>TW-511</p>  <p>CABLE TENSION UNIT 电缆拉伸单元</p>	<p>TW-512(2.4)</p>  <p>CABLE FLEXIBLE TUBE 电缆软管</p>	<p>TW-701</p>  <p>S.P 상하 HOLDER S.P上下座</p>	<p>TW-711</p>  <p>수동 CARRIAGE 手动小车</p>
<p>TW-717</p>  <p>MARKING TORCH HOLDER 划线枪座</p>	<p>TW-717-1</p>  <p>MARKING TORCH L-BRACKET 划线枪L支架</p>	<p>TW-718</p>  <p>CUTTING HOLDER 切割支座</p>	<p>TW-718-1</p>  <p>L-BRACKET L型支架</p>
<p>TW-718-2</p>  <p>MARKING HOLDER 划线夹具</p>	<p>TW-751</p>  <p>WATER FLOWER CABLE 水流管</p>	<p>TW-754</p>  <p>FEEDING SCREW 送丝螺丝</p>	<p>TW-761</p>  <p>(大中小) MARKING CHAMBER 划线粉斗</p>

Plasma Manufactured List 等离子切割产品辅具

TW-773  CENTER HOLDER 中心夹具	TW-774  MARKING CENTER PIN 中心划线销	TW-930  EDGE ROLLER 切割面回转滚轴	TW-944  AUTO IGNITOR 自动点火器
TW-AC238  PLASMA ARC CURTAIN 等离子挡弧板	TW-ARM100  ROTATION ARM 旋转臂	TW-BLT02  SUS BALL 不锈钢球	TW-BT100  BEVEL TORCH BLOCK 斜面焊枪挡块
TW-G80100  INITIAL SENSOR ASS'Y 初级感应总成	TW-G9010  TWIN HEATING HOLDER 双头加热夹具	TW-LK100  LINK UNIT ASS'Y 链接单元总成	TW-LINK500  3D LINK ASS'Y 3D链接总成
TW-MPD25  BLUE ZINK MARKING POWDER 锌粉	TW-M901  GUIDE ROLLER 导向轮	TW-MTH82  MAGNET TORCH HOLDER 磁力割枪夹具	TW-PM125/130  PINION GEAR 齿轮
TW-RB3.0/4.3  면취용 CUTTER 气动工具	TW-SSFD10  FUME DUCTOR 烟道	TW-TH81  NEW TORCH HOLDER 新割枪夹具	TW-PB-S76/PB-S77  KJELLBERG TORCH 凯尔贝割枪
TW-PB-S75  ROBOT TORCH 机器人用割枪	TW-4100  4100 TORCH ASS'Y 4100枪炬总成	TW-4400  4400 TORCH ASS'Y 4400枪炬总成	TW-254  254 TORCH ASS'Y 254枪炬总成
TW-400  400 TORCH ASS'Y 400枪炬总成	TW-401  401 TORCH ASS'Y 401枪炬总成	TW-402  402 TORCH ASS'Y 402枪炬总成	TW-410  410 TORCH ASS'Y 410枪炬总成
TW-434  434 TORCH ASS'Y 434枪炬总成	TW-600  600 TORCH ASS'Y 600枪炬总成	TW-19XL  19XL TORCH ASS'Y 19XL枪炬总成	TW-PT600  PT600 TORCH ASS'Y PT600枪炬总成

Gas Cutting Spare

气体切割配件

Gas Cutting Spare



MARKING CHAMBER SET (KOIKE)
整套划线粉斗 (KOIKE)



BEVEL TORCH BLOCK
倾斜割枪垫块



MARKING CHAMBER SET (HYPER THERM)
整套划线粉斗 (HYPER THERM)



MARKING CHAMBER SET (TANAKA)
整套划线粉斗 (TANAKA)



TWIN TORCH
孪生割枪



GAS TIP HOLDER
火焰喷嘴支架

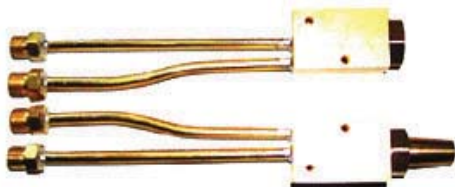

AIR SENSOR
气体传感器



HEIGHT SENSOR SET
高度感应总成

Marking Spare

划线消耗件

Marking Spare

TW-MPD25 [MARKING POWDER]



BLUE POWDER
蓝色划线粉末
500g / 200g

ZINC POWDER
白色划线粉末
1 Kg

TW-131-4 [MARKING TIP] 划线嘴



Marking Spare | 划线消耗件



VULCAN 渤洱康自动化设备（上海）有限公司
Engineering & Systems VULCAN AUTOMATIC EQUIPMENT (SHANGHAI) CO., LTD

地 址：上海市松江区新桥镇新茸路松南工业小区16号（201612）

电 话：021-67687277, 67687278

传 真：021-67687276

E-mail: biz@vulcantrade.com.cn

网 址：www.vulcantrade.com.cn

Add: No.16 Songnan Industrial Park, Xinrong Rd., Xinqiao,
Songjiang, Shanghai, China (201612)

Tel: +86-21-67687277, 67687278 Fax: +86-21-67687276

E-mail: biz@vulcantrade.com.cn

Http: www.vulcantrade.com.cn

■ AGENT

